

## Dual Intercooler Temp Gauge

DIGITAL DUAL INTERCOOLER TEMP GAUGE  
DISPLAY RANGE :  
50 ~ 300 °F

Part Number: 1TR1AA006R

### 1 Check and verify all included items:

- (1) 52mm Dual Intercooler Temp Gauge
- (1) Power Harness
- (2) Air Temperature sensors and wiring harness
- (1) Mounting Pod
- (1) Sun Shade (Hood)
- (1) 3M double sided tape
- (2) Mounting Bracket Threaded Extension
- (2) Washers
- (2) Nuts
- (1) Mounting Bracket

\*NOTE  
Installation of the temperature sensors require 3/8 NPT weld-in bungs. These bungs are not included.

### 2 Make sure the car is turned off and disconnect the battery before attempting any electrical work.

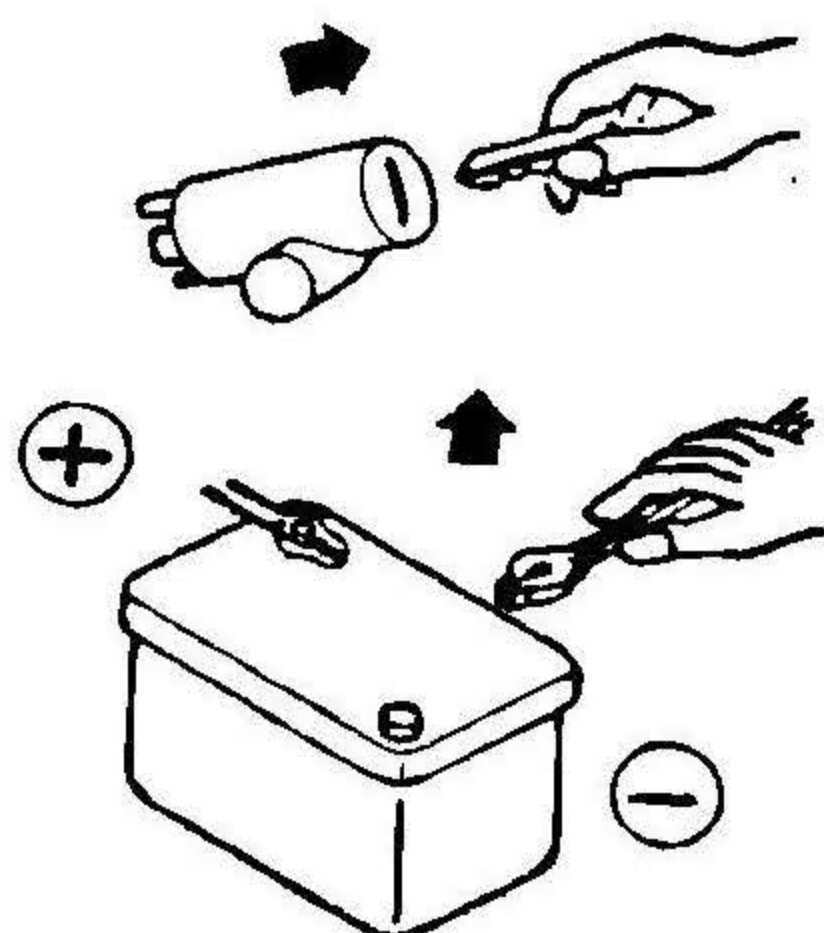

### 3 Optional mounting bracket:

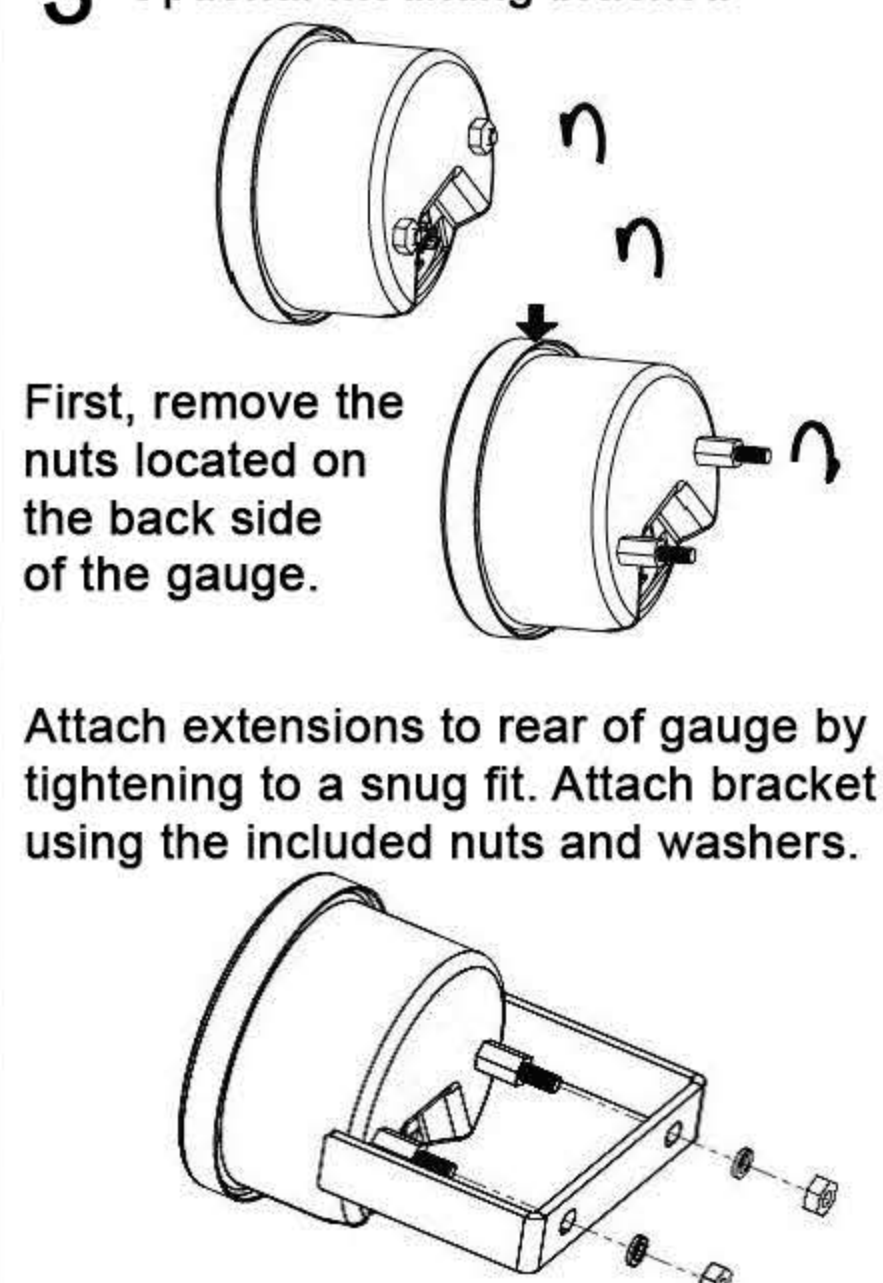

### 4 Plug power wire harness to rear of gauge.

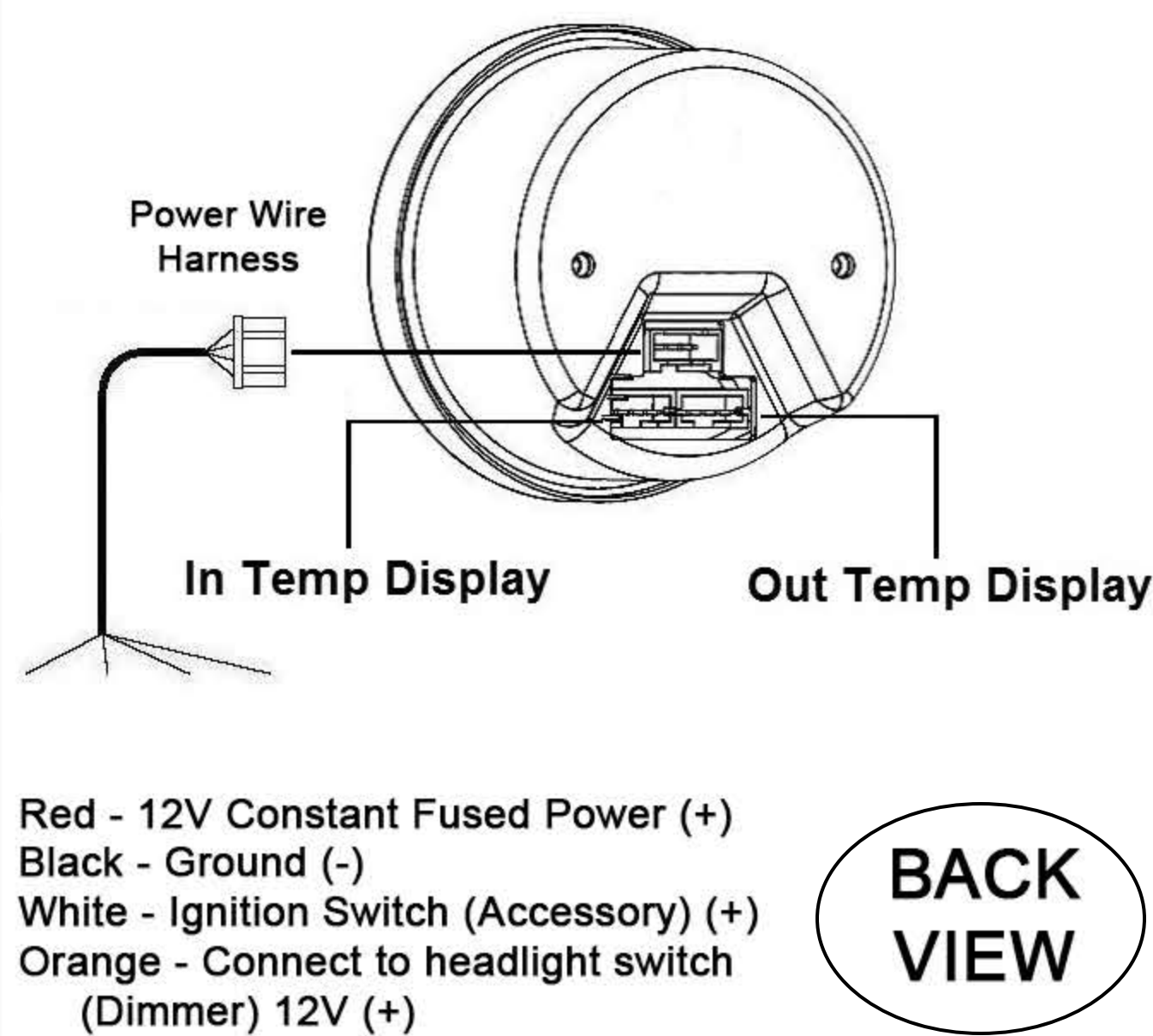

### 5 Air Intake Temp Sensor

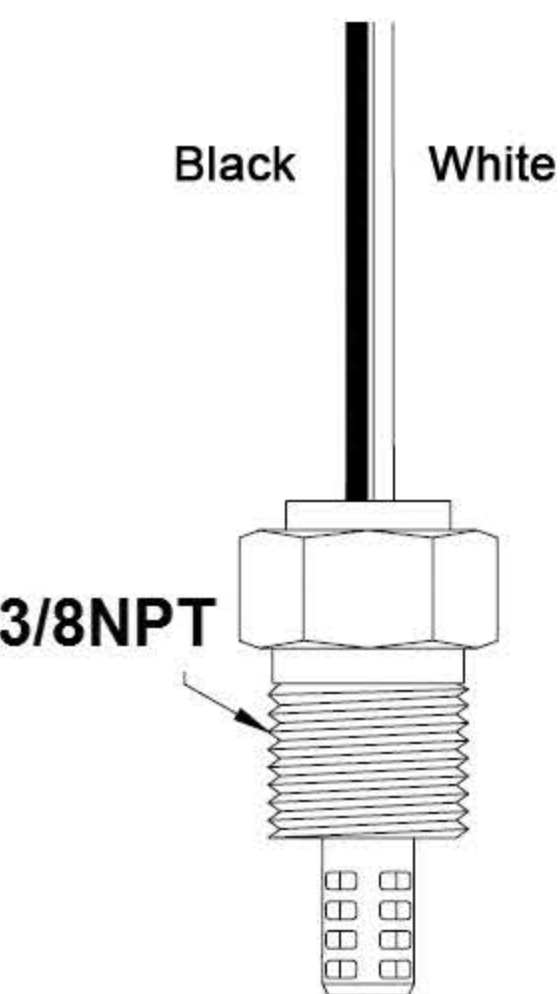

### 6 3/8 NPT weld-in bungs of the appropriate material are required to install the sensors onto the piping. \*These bungs are not included.

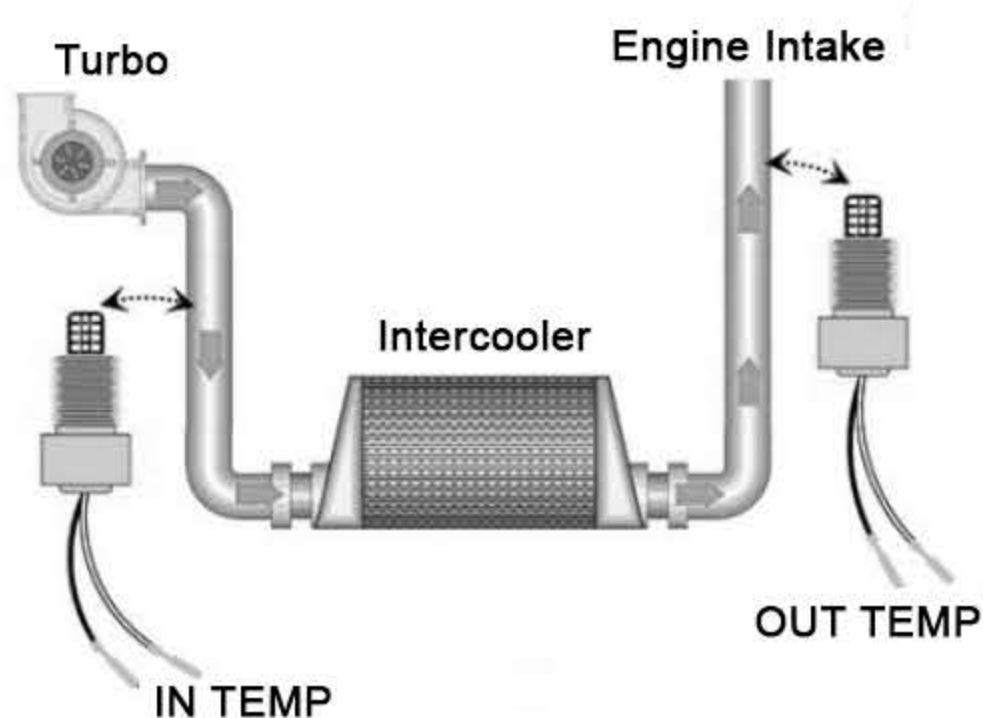

- The "IN TEMP" side sensor must be installed after the turbo and before the intercooler.
- The "OUT TEMP" side sensor must be installed after the intercooler and before the engine intake.

### 7 Plug harness sensors to rear of gauge.

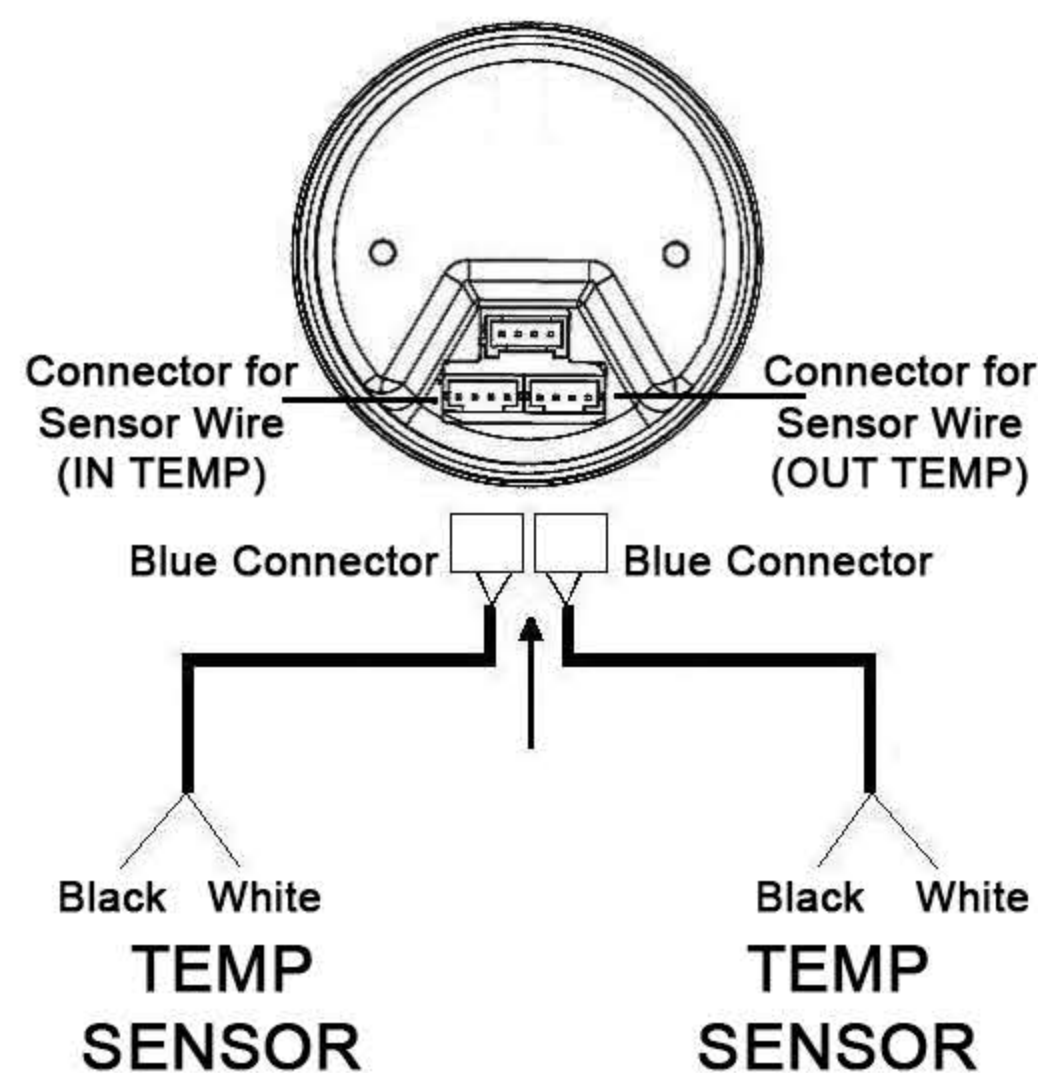

### 8 Reconnect the battery terminals.

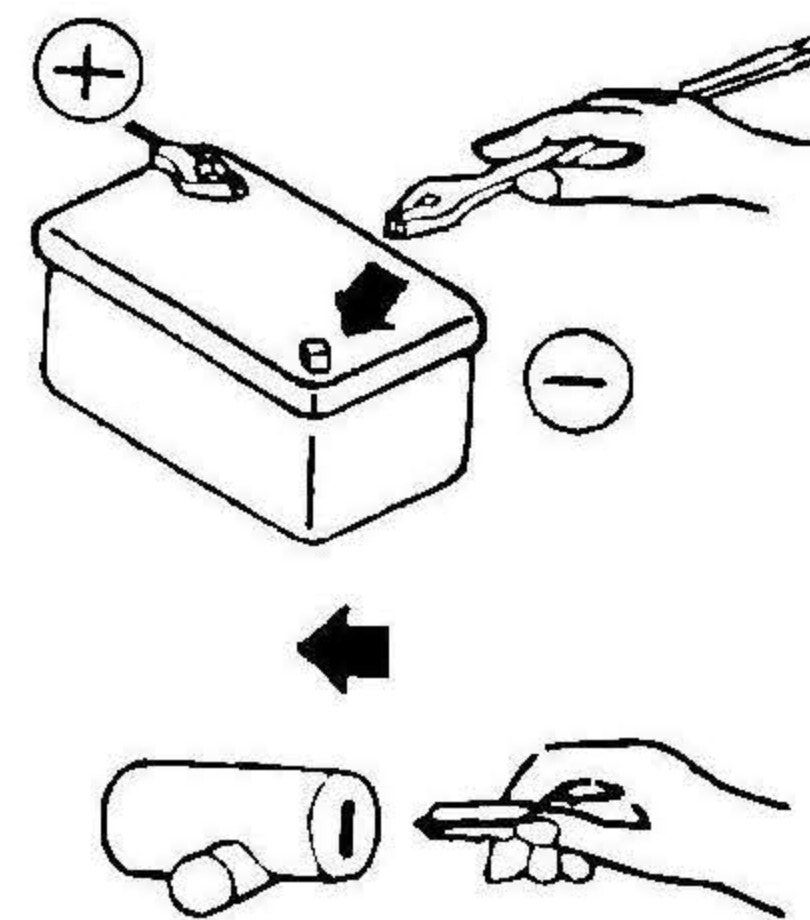

## Voltage Gauge

DIGITAL VOLTAGE GAUGE  
DISPLAY RANGE :  
8 ~ 18 V

Part Number: 1TR1AA007R

### 1 Check and verify all included items:

- (1) 52mm Voltage Gauge
- (1) Power Harness
- (1) Daisy Chain Harness
- (1) Mounting Pod
- (1) Sun Shade (Hood)
- (1) 3M double sided tape
- (2) Mounting Bracket Threaded Extension
- (2) Washers
- (2) Nuts
- (1) Mounting Bracket

\*VLS gauges are daisy chain compatible only with VLS OLED gauges.

### 2 Make sure the car is turned off and disconnect the battery before attempting any electrical work.

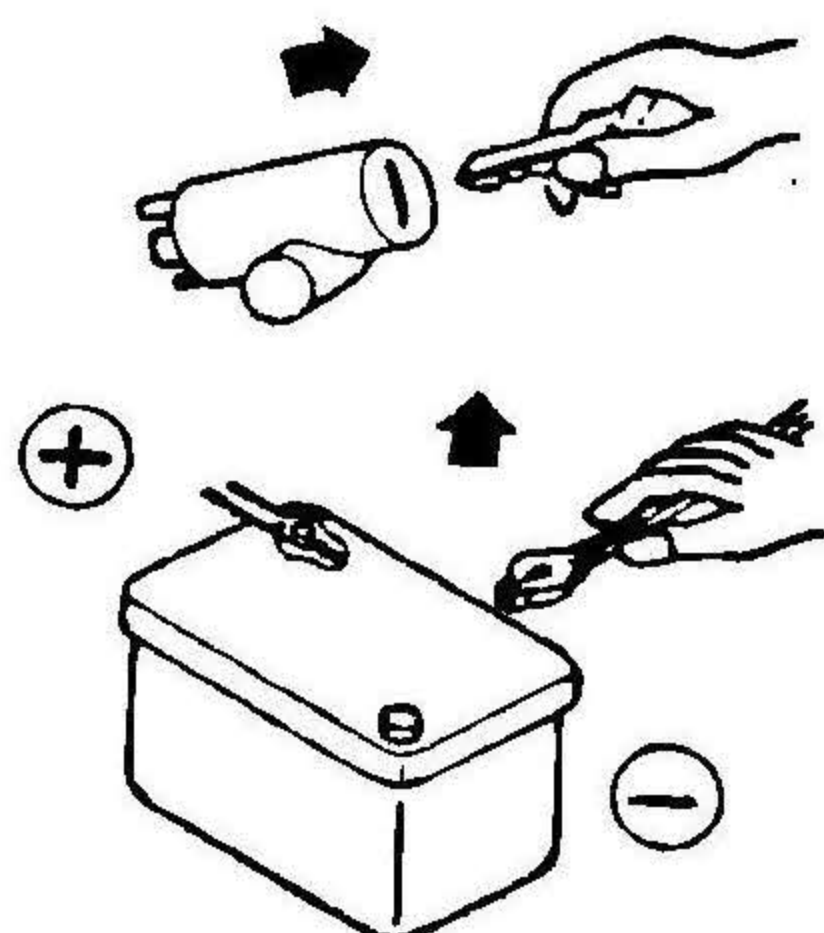

### 3 Optional mounting bracket:

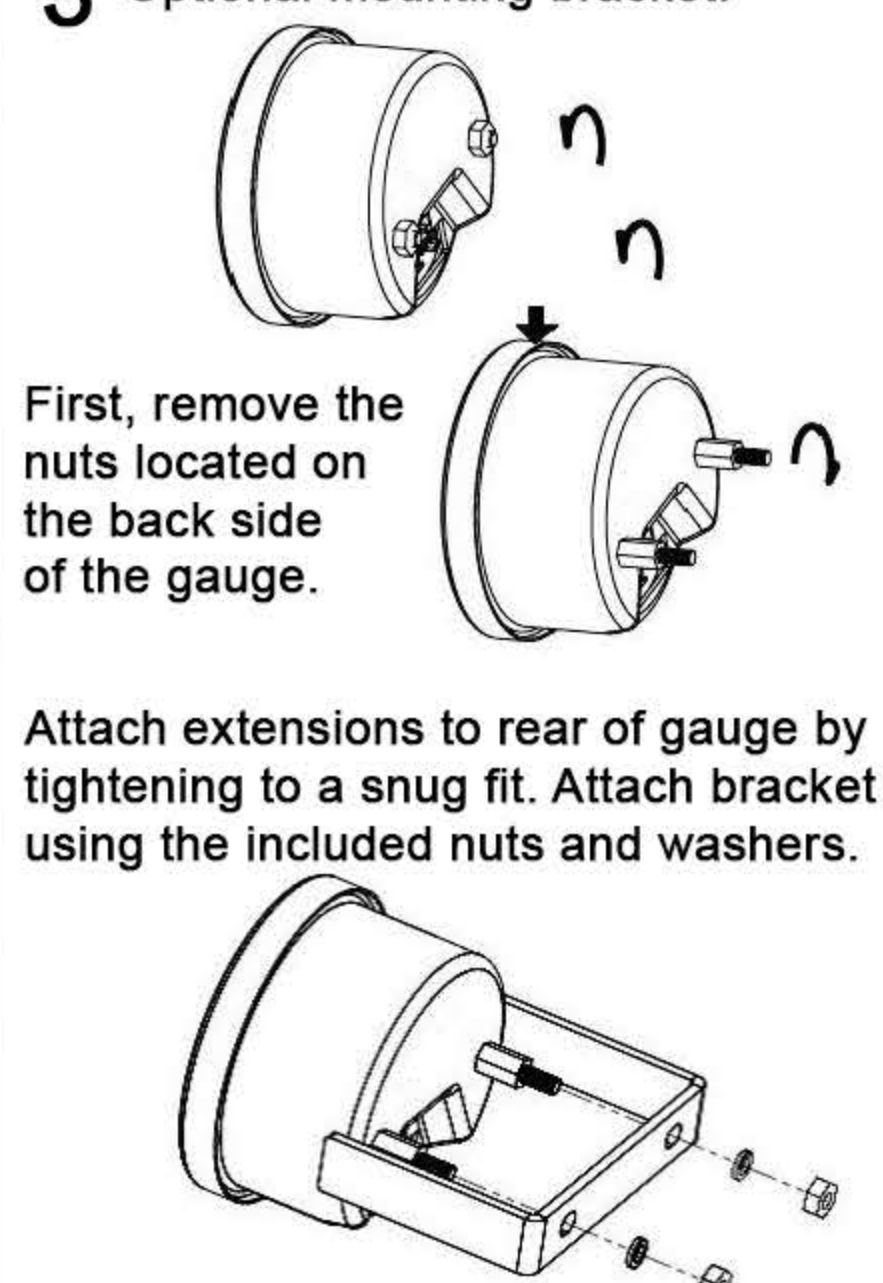

### 4 Plug power wire harness to rear of gauge. Then reconnect the battery.

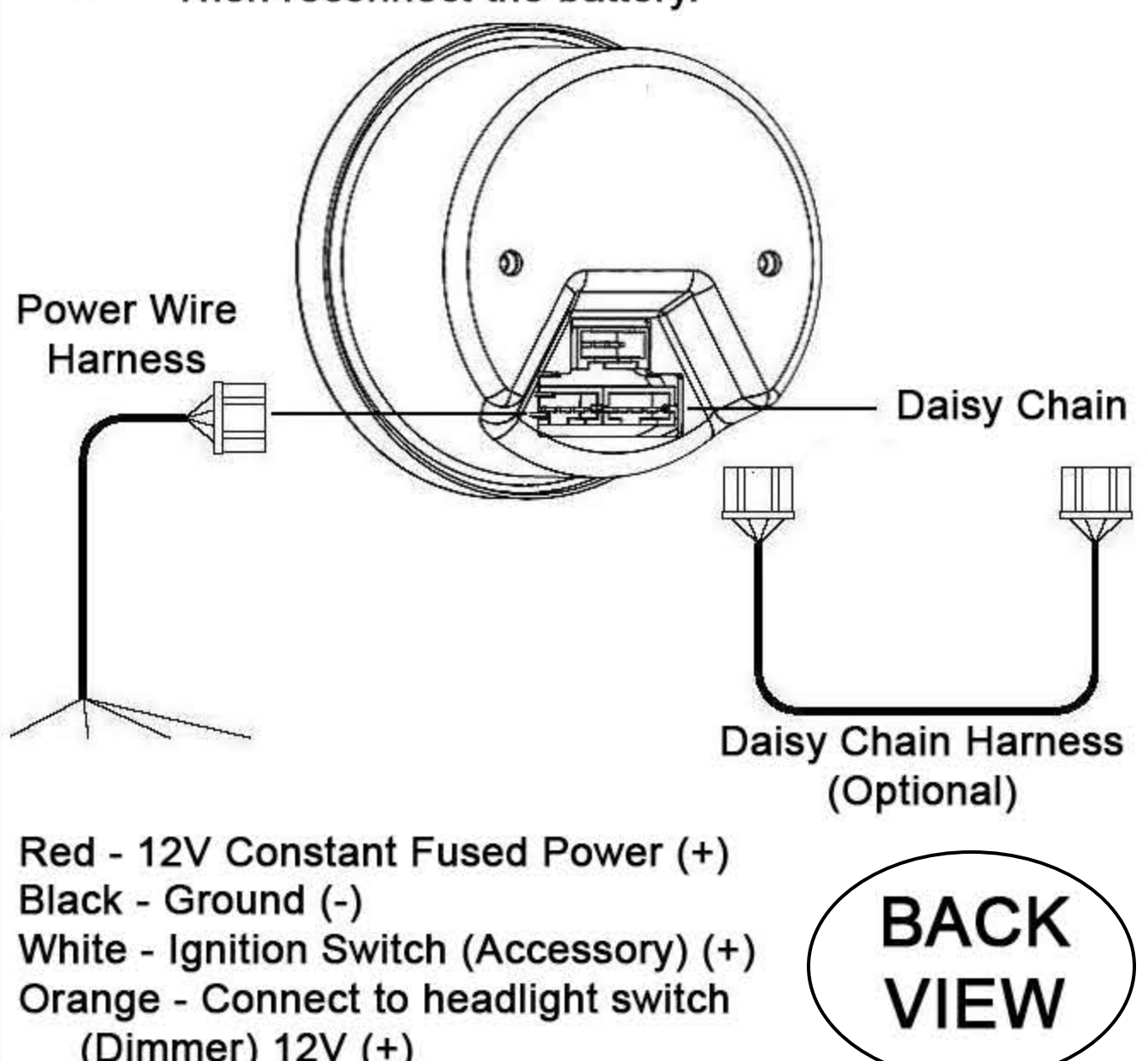

## Limited Warranty

We warrant all of our parts against defects in materials or workmanship under normal use and service after proper installation, (subject to the conditions and exclusions described below) for a period of one (1) year from the original consumer's date of purchase. During the warranty period, we will, at our option, repair or replace the defective part or refund your money. This warranty does not cover labor reimbursement. This warranty is non-transferrable. Replacement parts are warranted from the date of exchange for a period of one (1) year. The following is a non-exclusive list of examples that are not considered defects: failure due to accident or collision, chemical fallout, corrosion due to salt or other environmental conditions including natural disasters; improper installation, self-installation, or modification of the part; vehicles under manufacturer's recall for a related problem; and misuse or abuse, including off-road driving or racing.

THIS WARRANTY DOES NOT COVER INCIDENTAL, INDIRECT, SPECIAL OR CONSEQUENTIAL DAMAGES SUCH AS PHYSICAL INJURIES OR PROPERTY DAMAGE, LOSS OF TIME, LOSS OF USE OF THE VEHICLE, INCONVENIENCE, RENTAL VEHICLE CHARGES, TOWING CHARGES OR ACCOMMODATIONS RESULTING FROM A DEFECT IN OR FAILURE OF THE PART. THIS WARRANTY REPRESENTS THE EXCLUSIVE REMEDY FOR ANY PRODUCT DEFECT OR FAILURE AND THE MANUFACTURER MAKES NO OTHER WARRANTIES EXPRESS OR IMPLIED INCLUDING ANY WARRANTY OF MERCHANTABILITY, CONDITION OF ANY KIND, OR FITNESS FOR A PARTICULAR PURPOSE. Some states do not allow disclaimers of implied warranties, and in those states any implied warranty that may apply is limited to one year. If any provision of the warranty should be deemed invalid or unenforceable, the remaining terms and provisions of the warranty shall remain in full force and effect.

To file a claim:  
You must obtain a Return Authorization from the original place of purchase prior to returning parts for inspection for defects. Returns must accompany the original consumer's sales receipt. The R.A. number must be written on the outside of the carton to be returned. Any carton without a proper R.A. number will be refused. An R.A. does not guarantee repair, replacement or refund, only that the manufacturer will inspect the parts for defects. Returns must be sent by pre-paid freight.